

*TB 9-6625-2316-24

DEPARTMENT OF THE ARMY TECHNICAL BULLETIN

CALIBRATION PROCEDURE FOR TELEPHONE CABLE TEST SET (TCTS) AN/GTM-12

Headquarters, Department of the Army, Washington, DC

25 March 2008

Distribution Statement A: Approved for public release, distribution is unlimited.

REPORTING OF ERRORS AND RECOMMENDING IMPROVEMENTS

You can improve this manual. If you find any mistakes or if you know of a way to improve these procedures, please let us know. Mail your letter or DA Form 2028 (Recommended Changes to Publications and Blank Forms) directly to: Commander, U.S. Army Aviation and Missile Command, ATTN: AMSAM-MMC-MA-NP, Redstone Arsenal, AL 35898-5000. A reply will be furnished to you. You may also send in your comments electronically to our E-mail address: 2028@conus.army.mil or by fax 256-842-6546/DSN 788-6546. For the World Wide Web use: <https://amcom2028.redstone.army.mil>. Instructions for sending an electronic 2028 can be found at the back of this manual.

SECTION		Paragraph	Page
	I. IDENTIFICATION AND DESCRIPTION		
	Test instrument identification	1	2
	Forms, records, and reports	2	2
	Calibration description	3	2
	II. EQUIPMENT REQUIREMENTS		
	Equipment required	4	2
	Accessories required	5	3
	III. CALIBRATION PROCESS		
	Preliminary instructions	6	3
	Equipment setup	7	4
	Continuity	8	4
	Insulation resistance (100 k Ω).....	9	6
	Insulation resistance (10 M Ω).....	10	6
	Crosstalk	11	7
	Final procedure.....	12	8

*This bulletin supersedes TB 9-6625-2316-35, dated 18 November 1996.

SECTION I IDENTIFICATION AND DESCRIPTION

1. Test Instrument Identification. This bulletin provides instructions for the calibration of Telephone Cable Test Set (TCTS), AN/GTM-12. The manufacturer's manual and TM 11-6625-3292-40 were used as prime data sources in compiling these instructions. The equipment being calibrated will be referred to as the TI (test instrument) throughout this bulletin.

a. Model Variations. None.

b. Time and Technique. The time required for this calibration is approximately 4 hours, using the dc and low frequency and microwave techniques.

2. Forms, Records, and Reports

a. Forms, records, and reports required for calibration personnel at all levels are prescribed by TB 750-25.

b. Adjustments to be reported are designated (R) at the end of the sentence in which they appear. When adjustments are in tables, the (R) follows the designated adjustment. Report only those adjustments made and designated with (R).

3. Calibration Description. TI parameters and performance specifications which pertain to this calibration are listed in table 1.

Table 1. Calibration Description

Test instrument parameters	Performance specifications
Continuity	Range: <20 Ω per 250 ft. of cable; maximum of <160 Ω for 2000 ft. Accuracy: $\pm 2.0\%$
Insulation	Range: >100 k Ω Accuracy: $\pm 2.0\%$
Resistance	Range: >10 M Ω Accuracy: $\pm 3.0\%$
Crosstalk	Range: <-25 dB Accuracy: $\pm 2.0\%$

SECTION II EQUIPMENT REQUIREMENTS

4. Equipment Required. Table 2 identifies the specific equipment to be used in this calibration procedure. This equipment is issued with Secondary Transfer Calibration Standards Sets AN/GSM-286, AN/GSM-287 or AN/GSM-705. Alternate items may be used by the calibrating activity. The items selected must be verified to perform satisfactorily prior to use and must bear evidence of current calibration. The equipment must meet or exceed the minimum use specifications listed in table 2. The accuracies listed in table 2 provide a four-to-one ratio between the standard and TI.

5. Accessories Required. The accessories required for the calibration are common usage accessories, issued as indicated in paragraph 4 above, and are not listed in this calibration procedure. The following peculiar accessories are also required for this calibration: Extender Card, part number 385E302; Electric Connector Assembly, part number M55074/4 (NSN 5935-01-142-9742).

Table 2. Minimum Specifications of Equipment Required

Common name	Minimum use specifications	Manufacturer and model (part number)
MULTIMETER	Range: Dc voltage: (30 mV to 3.0 V) Resistance: (1000Ω to 3000Ω) Accuracy: ±0.5%	Fluke, Model 8840A/AF05 (AN/GSM-64D)
OSCILLOSCOPE	Range : Observe 1000 Hz signal Accuracy: ±0.5%	Agilent, OS-303/G (OS-303/G)
RESISTANCE STANDARD NO. 1	Range: 16.78 kΩ Accuracy: ±0.5%	Biddle-Gray, Model 71-650 (71-650)
RESISTANCE STANDARD NO. 2	Range: 19.6Ω to 700 kΩ Accuracy: ±0.5%	Biddle-Gray, Model 71-631 (7910328)
RESISTANCE STANDARD NO. 3	Range: 9 and 10 MΩ Accuracy: ±0.75%	Beckman, Model CR10M (8598965)

SECTION III CALIBRATION PROCESS

6. Preliminary Instructions

a. The instructions outlined in paragraphs 6 and 7 are preparatory to the calibration process. Personnel should become familiar with the entire bulletin before beginning the calibration.

b. Items of equipment used in this procedure are referenced within the text by common name as listed in table 2.

c. Unless otherwise specified, verify the result of each test and, whenever the test requirement is not met, take corrective action before continuing with the calibration. Additional maintenance information is contained in the TM 11-6625-3292-40 and the manufacturer’s manual for this TI.

d. Unless otherwise specified, all controls and control settings refer to the TI.

7. Equipment Setup

WARNING

HIGH VOLTAGE is used or exposed during the performance of this calibration. DEATH ON CONTACT may result if personnel fail to observe safety precautions. REDUCE OUTPUT(S) to minimum after each step within the performance check where applicable.

- a. Connect adapter cable W100, supplied with TI, to J100 connector; then connect electric connector assembly to the other end of adapter cable.
- b. Connect power cable to the power connector and to a 115 ac power source.
- c. Set **POWER** switch to **A.C.**

8. Continuity

a. Performance Check

- (1) Set the **FUNCTION** switch to **CONT. P.**
- (2) Set the **CABLE LENGTH** switch to **250.**
- (3) Set **AUTO/SINGLE** switch to **SINGLE.**
- (4) Press the **RESET** pushbutton.
- (5) Set resistance standard No. 2 for 20.4 Ω and connect between pins 1A and 1B (fig. 1) of the electric connector assembly (connected to end of adapter cable).
- (6) Press the **ADVANCE** pushbutton once to test circuit **01.** TI **TEST** light and **FAULT** light will be on; if not, perform **b** below.
- (7) Press the **RESET** pushbutton and set resistance standard No. 2 for 19.6 Ω .
- (8) Press the **ADVANCE** pushbutton once to test circuit **01.** TI **FAULT** light will remain off; if not, perform **b** below.
- (9) Press the **RESET** pushbutton.

b. Adjustments

- (1) Set **POWER** switch to **OFF** and disconnect power cable from ac power source.
- (2) Remove TI from its casing. Remove the end plate (located near the interface connector J100). Ensure that potentiometers R1, R2, and R3 and the test points TP1, TP2, and TP3, located on A3 measurement card, are readily accessible (fig. 1).
- (3) Reconnect TI to ac source and set **POWER** switch to **A.C.**
- (4) Set the **FUNCTION** switch to **CONT. P.**
- (5) Set the **CABLE LENGTH** switch to **250.**
- (6) Set **AUTO/SINGLE** switch to **SINGLE.**
- (7) Press the **RESET** pushbutton.

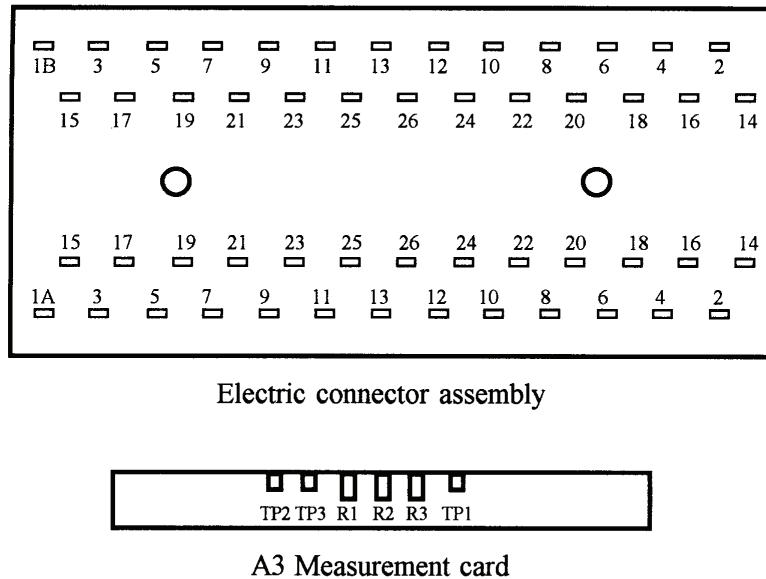

Figure 1. Test and connection points and adjustments.

(8) Press the **ADVANCE** pushbutton once; circuit **01** will be under test, **FAULT** light and **TEST** light should be on.

(9) Set resistance standard No. 2 for $20.0\ \Omega$ and connect between pins 1A and 1B (fig. 1) of the electric connector assembly (connected to end of adapter cable).

(10) Monitor dc voltage at TP2 with the multimeter using the cage as the ground reference.

(11) Adjust R1 so that the voltage at TP2 is about 2.5 V (this voltage is unstable and just between the high and low crossover points) (R).

(12) Press the **RESET** pushbutton and disconnect resistance standard No. 2.

(13) Set **FUNCTION** switch to **IR (0.1M)**.

(14) Set **AUTO/SINGLE** switch to **SINGLE**.

(15) Press the **ADVANCE** pushbutton once; the **TEST** light should be on and the **FAULT** light should be off.

(16) Set resistance standard No. 2 for $100\ \text{k}\Omega$ and connect between pins 1A and 1B (fig. 1) of the electric connector assembly (connected to end of adapter cable).

(17) Use the multimeter to measure dc voltage at TP1, with the cage as ground reference. The voltage should be about 900 mV; record the exact reading.

(18) Monitor the dc voltage reading at TP3; if it is different from that at TP1, adjust R3 so that voltage at TP3 is the same ($\pm 1\ \text{mV}$) as that at TP1 (R).

(19) Press the **RESET** pushbutton and disconnect resistance standard No. 2.

- (20) Set **FUNCTION** switch to **IR (10M)**.
- (21) Set **AUTO/SINGLE** switch to **SINGLE**.
- (22) Press the **ADVANCE** pushbutton once; the **TEST** light should be on and the **FAULT** light should be off.
- (23) Connect resistance standard No. 3 for 10 M Ω and connect between pins 1A and 1B (fig. 1) of the electric connector assembly (connected to end of adapter cable).
- (24) Use the multimeter to measure dc voltage at TP1, with the cage as ground reference. The voltage should be about 360 mV; take the exact reading.
- (25) Take the voltage reading at TP3. If it is different from that at TP1, adjust R2 so that voltage at TP3 is the same (± 1 mV) as that at TP1 (R).
- (26) Press the **RESET** pushbutton and disconnect resistance standard No. 3.
- (27) Repeat **8 a** above (and **9 a** and **10 a** below, if applicable).

9. Insulation Resistance (100 k Ω)

a. Performance Check

- (1) Set **FUNCTION** switch to **IR (0.1M)**.
- (2) Set **AUTO/SINGLE** switch to **SINGLE**.
- (3) Press the **RESET** pushbutton.
- (4) Set resistance standard No. 2 for 102 k Ω .
- (5) Press the **ADVANCE** pushbutton once to test circuit **A01**. TI **TEST** light will be on and the **FAULT** light will remain off; if not, perform **b** below.
- (6) Press the **RESET** pushbutton and set resistance standard No. 2 for 98 k Ω .
- (7) Press the **ADVANCE** pushbutton once to test circuit **A01**. TI **FAULT** light will be on; if not, perform **b** below.
- (8) Press the **RESET** pushbutton and disconnect resistance standard No. 2.

b. Adjustments. Perform **8 b** above, if not previously performed. Otherwise, no other adjustments can be made.

10. Insulation Resistance (10 M Ω)

a. Performance Check

- (1) Set **FUNCTION** switch to **IR (10M)**.
- (2) Set **AUTO/SINGLE** switch to **SINGLE**.
- (3) Press the **RESET** pushbutton.
- (4) Connect resistance standard No. 3 in series with resistance standard No. 2 and set for a total resistance value of 10.3 M Ω .
- (5) Press the **ADVANCE** pushbutton once to test circuit **A01**. TI **TEST** light will be on and the **FAULT** light will remain off; if not, perform **b** below.

(6) Press the **RESET** pushbutton and set resistance standard No. 2 and No. 3 for a total resistance of 9.7 M Ω .

(7) Press the **ADVANCE** pushbutton once to test circuit **A01**. **TI FAULT** light will be on; if not, perform **b** below.

(8) Press the **RESET** pushbutton and disconnect resistance standards No. 2 and No. 3.

b. Adjustments. Perform **8 b** above, if not previously performed. Otherwise, no other adjustments can be made.

11. Crosstalk

a. Performance Check

(1) Set **FUNCTION** switch to **XTALK**. Ensure that no other equipment is connected to TI.

(2) Set **AUTO/SINGLE** switch to **AUTO**.

(3) Press the **ADVANCE** pushbutton once. The **TI TEST** light will be flashing on and off as each pair combination is being tested, beginning with **01 - 01** and ending with **26 - 26**. The **FAULT** light should remain off, and upon completion, the **END** light should temporarily come on. If the **FAULT** light comes on, perform **b** below.

b. Adjustments

(1) Press the **RESET** pushbutton.

(2) Set **AUTO/SINGLE** switch to **SINGLE**.

(3) Set **POWER** switch to **OFF**. Remove TI from its casing. Remove the end plate (located near the interface connector J100). Ensure that potentiometers R1, R2, and R3 and the test points TP1, TP2, and TP3, located on A3 measurement card, are readily accessible (fig. 1).

(4) Set **POWER** switch to **ON**.

(5) Set resistance standard No. 1 for 16.78 k Ω and connect between pin 1A and pin 2A (fig. 1). Set resistance standard No. 2 for 16.78 k Ω and connect between pin 1B and pin 2B (fig. 1).

(6) Press **ADVANCE** pushbutton a few times until circuits **01 02** are under test.

(7) Measure the dc voltages at TP-1 and TP-2. If the two readings are within 0.5% of each other, the crosstalk detector is in good operating condition. Repeat **11 a** above after disconnecting both standard resistors from TI.

(8) If the readings differ from each other more than 0.5%, perform paragraphs (9) through (16) below.

(9) Reset the test set and disconnect standard resistors No. 1 and No. 2.

(10) Set **POWER** switch to **OFF**.

(11) Remove the A3 measurement circuit card, insert the extender card, and then insert measurement card on to the extender card.

(12) Gain Setting for IR Tests. In IR tests, the gain of the instrumentation amplifier U64 (INA 101SM) is set at 40. With system power off, adjust R50 so that the total resistance between pin 4 and pin 1 of U64 is 1025.6Ω (R).

(13) Gain Settings for Crosstalk Tests. In crosstalk tests, the detected crosstalk signals are magnified by 17.78 times (equivalent to 25 dB) and then compared with the exciting signals. The gain of the instrumentation amplifier U31 (INA 101SM) is set by adjusting R20. With the system power off, adjust R20 so that the resistance between pin 1 and pin 4 of U31 is 2383.9Ω (R).

(14) Crosstalk Stimuli Waveform Adjustments. The crosstalk test stimuli (1000 Hz complementary sine waves) are generated from the crystal-controlled oscillator counter U55 (MC54HC4060J) output, which is 1000 Hz square wave. It goes through a wave-shaping circuit to become a trapezoidal wave then through an active filter circuit to provide sine wave stimuli. R30 is the potentiometer used to shape the trapezoidal wave so that the sine wave stimulus has the least harmonic content. Use an oscilloscope to aid in adjusting the trapezoidal waves.

(a) Turn on the system power and set the **FUNCTION** switch to **XTALK**.

(b) Observe the wave form at pin 1 of U55. Note that a 1000 Hz square wave is observed.

(c) Observe the waveform at pin 14 of U35. Note that the waveform is a trapezoidal wave (1000 Hz).

(d) Adjust R30 so that the wave has 0.167 ms wide flat top (or flat bottom) (R).

(e) Check for sine wave at pin 6 of U 15 and its complementary sinewave at pin 6 of U16.

(15) When the procedures are completed, turn off the system power, remove the extender card/cable, and insert the measurement card back into the card cage.

(16) Repeat/perform paragraphs 7 through 11 above.

12. Final Procedure

a. Deenergize and disconnect all equipment.

b. Annotate and affix DA label/form in accordance with TB 750-25.

By Order of the Secretary of the Army:

Official:



JOYCE E. MORROW
*Administrative Assistant to the
Secretary of the Army*

0802809

GEORGE W. CASEY, JR.
*General, United States Army
Chief of Staff*

Distribution:

To be distributed in accordance with the initial distribution number (IDN) 344600, requirements for calibration procedure TB 9-6625-2316-24.

Instructions for Submitting an Electronic 2028

The following format must be used if submitting an electronic 2028. The subject line must be exactly the same and all fields must be included; however, only the following fields are mandatory: 1, 3, 4, 5, 6, 7, 8, 9, 10, 13, 15, 16, 17, and 27.

From: "Whomever" whomever@conus.army.mil
To: <2028@conus.army.mil>

Subject: DA Form 2028

1. **From:** Joe Smith
2. **Unit:** home
3. **Address:** 4300 Park
4. **City:** Hometown
5. **St:** MO
6. **Zip:** 77777
7. **Date Sent:** 19-OCT-93
8. **Pub no:** 55-2840-229-23
9. **Pub Title:** TM
10. **Publication Date:** 04-JUL-85
11. **Change Number:** 7
12. **Submitter Rank:** MSG
13. **Submitter FName:** Joe
14. **Submitter MName:** T
15. **Submitter LName:** Smith
16. **Submitter Phone:** 123-123-1234
17. **Problem:** 1
18. **Page:** 2
19. **Paragraph:** 3
20. **Line:** 4
21. **NSN:** 5
22. **Reference:** 6
23. **Figure:** 7
24. **Table:** 8
25. **Item:** 9
26. **Total:** 123
27. **Text**

This is the text for the problem below line 27.

